

WATER FLOW REGULATORS

The World's Leading Water Flow Regulators

world of innovation



Flowcon plus

The intelligent flow controller from WITTMANN

Elektronics case for optional circuit boards and connector plugs to other **Flowcon plus** units (4 units possible, 12 circuits max. per unit).

Generously dimensioned channels guarantee little loss of pressure and high flow rates. The mold connections are executed as G 3/8" internal threads, thus allowing for an individual connection.

Specially developed fine regulating valve guarantees a temperatur control accuracy of $\pm 1^\circ\text{C}$.

Case made of het resistant plastics guarantees a permanent temperature resistancy at 120°C .



WITTMANN Kunststoffgeräte GmbH, based in Vienna, has for 40 years been the undisputed number one in the development and manufacture of water distribution systems for plastics processing. With their latest innovation, the company will be presenting the first example of a new generation of intelligent flow controllers – **Flowcon plus**. With its proportional valve and zero-wear flow measurement, the WITTMANN **Flowcon plus** ensures constant flow and a constant temperature, all achieved in reproducible fashion through the whole period of manufacture.

The design of the unit is based on the proven modular system of the flow controller series **110** and **310**: 2 to 12 circuits per unit (in steps of 2 circuits).

The protective covers are easy to remove.

Flow sensor and temperature sensor are integrated in in the plastics case in a space-saving.

Non-corrosive main connections: G 1 1/4", made of brass, plastics coated.

Flowcon plus

Operation and control

Operation via the machine monitor

Whilst **Flowcon plus** is versatile in its applications, the ideal solution is to use it in conjunction with a WITTMANN BATTENFELD injection molding machine, which allows all WITTMANN peripherals to be fully integrated into the control system.



Operation via the WITTMANN remote control

Features of the remote control

- » Access to max. 4 **Flowcon plus** units with max. 12 circuits each (max. 48 circuits in total).
- » Touch screen 5,7" TFT display for maximum ease of use.
- » For the stand-alone versions of the equipment, WITTMANN provides this remote control system, which is connected to **Flowcon plus** via a serial port.

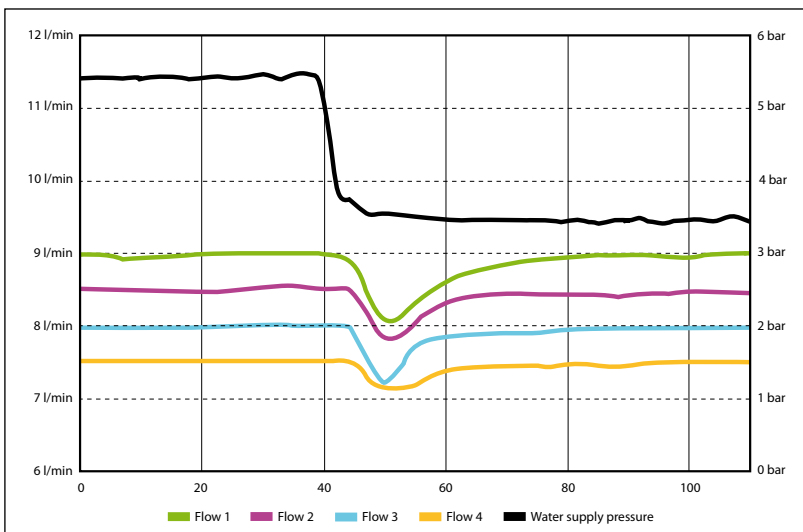

Process stability is achieved through

- » Disruptive factors, such as constriction of cooling ducts or fluctuations in pressure are detected and the flow is controlled proportionally using stepper motors instead of the old manual regulating valves.
- » Monitoring of preset flow and return channel temperature tolerances.
- » Isolated alarm contact.

Flowcon plus

proportionally controlled flow of 1-15 l

Use as distribution equipment

The housing components for **Flowcon plus** are made of high-quality plastic capable of withstanding temperatures of up to 120°C and allow water distribution equipment to be used as temperature control units. In this way, the flow can be matched to the dimensions of the cooling ducts, while permanent monitoring of multiple circuits is taking place. A uniform distribution of heat over the entire surface of the cavity is thereby obtained, which guarantees that the parts remain largely undistorted in the manufacturing process. If **Flowcon plus** is used in conjunction with a WITTMANN temperature control unit from the **Tempro basic C120** range – which allows for a flow of 280 liters per minute – it ensures that there is turbulence in the tool ducts, making it possible to provide the optimum dissipation of heat.

Advantages of mounting close to the mold

When the **Flowcon plus** is mounted close to the mold using solid mounting angles on the mounting plate of the injection molding machine, the losses in temperature and pressure are minimized.

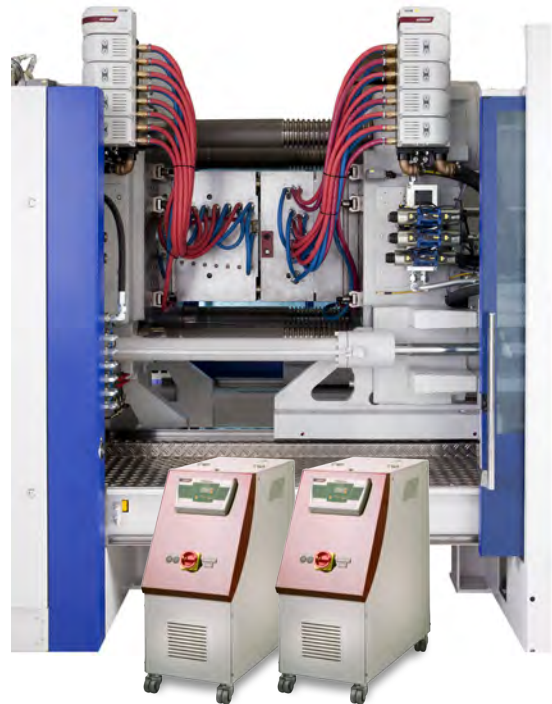

Flowcon plus	
Operating temperature	up to 120°C
Flow rate/circuit	1.5-15 l/min
Circuits/unit (steps of 2)	max. 12
Mold supply/return line	G 3/8"
Water supply/return line	G 1 1/4"
Electric connection I	24 V – DC (integrated solution)
Electric connection II	230 V – 50 Hz – AC – 4A (stand alone solution)

Dimensions / Distance = 52 mm		
	Measure A	Measure B
2 circuits	283	186
4 circuits	387	290
6 circuits	491	394
8 circuits	595	498
10 circuits	699	602
12 circuits	803	706

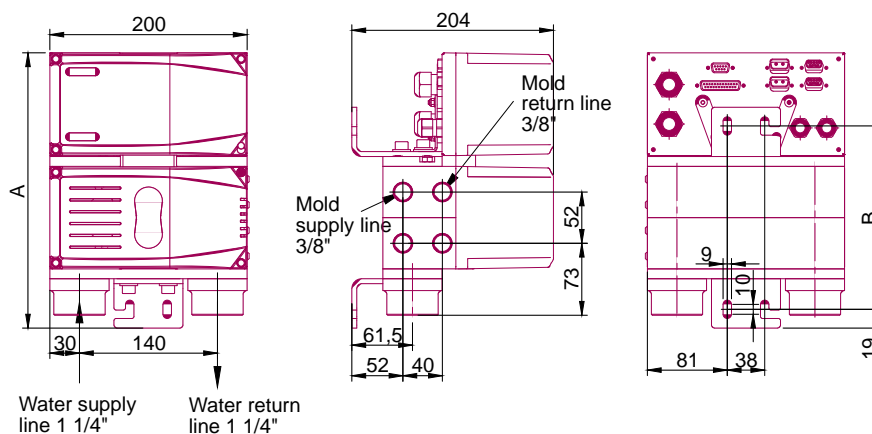

WFC 100

Water Flow Control up to 100°C

Monitoring and distributing

The **WFC** is the low-cost version of the **Flowcon plus**. This model does not offer the possibility to automatically readjust the flow rate.

The **WFC 100** is a pure control device for flow and temperature.

It is equipped with a maintenance-free flow measurement unit.

Manual control valves offer the possibility to readjust the flow of every single circuit.

The values for flow and temperature are displayed on a 7-segment display, and these values are controlled using the set tolerances.

The cases of the **WFC** device are made of high-quality hot pressed brass.

Standard equipment

- » 7-segment display with actual value display.
- » Flow and temperature monitoring for up to 8 circuits.
- » Control valves in mold forward line and return line.
- » Serial interface (20mA, RS232, RS485).
- » Isolated alarm contact.
- » Mounting angle.

WFC 100	
Operating temperature	max. 100°C
Pressure	max. 10 bar
Measurement	1,5-20 l/min
Mold connections	3/8"
Water supply and return	1 1/4"
Electric connection	24 V - 50/60 Hz
Execution	2, 4, 6 or 8 circuits
Option	230 V - 50/60 Hz



Dimensions / Distance = 60 mm		
	Measure A	Measure B
2 circuits	312	105
4 circuits	433	226
6 circuits	554	347
8 circuits	674	468

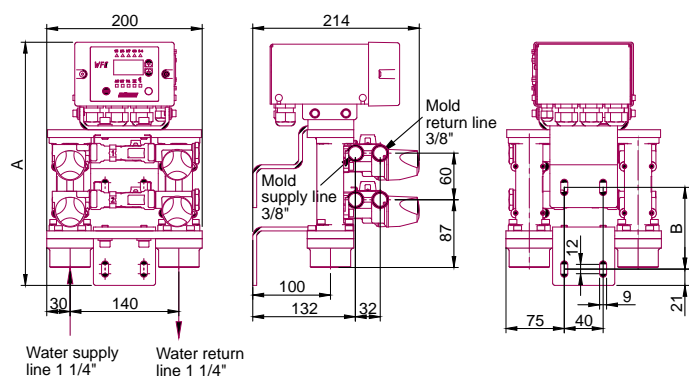

WFC 180

Water Flow Control up to 180°C

wilmann

Monitoring and distributing

The **WFC 180** does not offer the possibility to automatically readjust the flow rate.

The **WFC 180** is a pure control device for flow. It is equipped with a maintenance-free flow measurement unit.

The device is using the ultrasonic flow measuring method, and it offers an extremely high measurement precision, even at flow rates of less than 1 l/min. The flow rate of the single circuits can be readjusted using optional ball valves.

The values for flow and temperature are displayed on a 7-segment display, and these values are controlled using the set tolerances.

The cases of the **WFC** device are made of high-quality hot pressed brass.

Standard equipment

- » Remote control with 7-segment display with actual value display.
- » Flow monitoring for up to 8 circuits.
- » Serial interface (20mA, RS232, RS485).
- » Isolated alarm contact.
- » Mounting angle.
- » External sensor PT 100.

Option

Package: ball valves for manual regulation

WFC 180	
Operating temperature	max. 180°C
Pressure	max. 15 bar
Measurement	0,5-40 l/min
Mold connections	3/8"
Water supply and return	1"
Electric connection	24 V - 50/60 Hz
Execution	2 + 4 circuits
Option	230 V - 50/60 Hz

	Dimensions	
	Measure A	Measure B
2 circuits	350	199
4 circuits	471	320
6 circuits	592	441
8 circuits	713	562

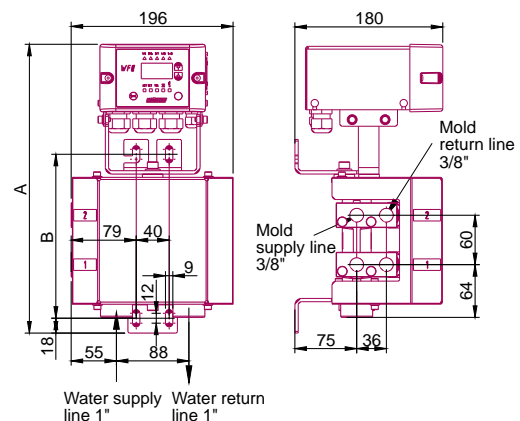

Series 110 and 310

The new flow regulator generation

The proven technology from WITTMANN, refined and in a new setting. Standard equipment in every injection molding machine for more than 40 years. Often copied, never equaled. With over 500,000 appliances sold the uncontested number 1! WITTMANN is now setting new benchmarks with the flow regulator series 110 and 310: further refined control technology combined with double sealing of the valve disk offers not only precise setting of the flow rate, but also lengthens the service life of the O-rings in the control valve.



The proven method of cleaning the pipe through the top part of the housing without removing the pipe has been kept unchanged for the series 110 and 310 too. An O-ring exchange can be carried out easily by lifting the pipe from the bracket and then pulling it through the housing.

Polyamide 12 is the best choice of material for use with hot water up to 100°C.

EPDM O-ring

The sensor tube of the thermometer is placed directly in the return water and thus responds very quickly to temperature fluctuations.

To minimize pressure loss inside the flow controller, the cross-sections have been designed as large as possible. With low system pressure, a minimal pressure loss rate is a decisive advantage.

The proven brass washers, the grommet 12 mm in diameter (standard for series 110) and threaded bushing made of brass (standard for series 310) are an absolute must and part of the basic equipment of a WITTMANN flow regulator.



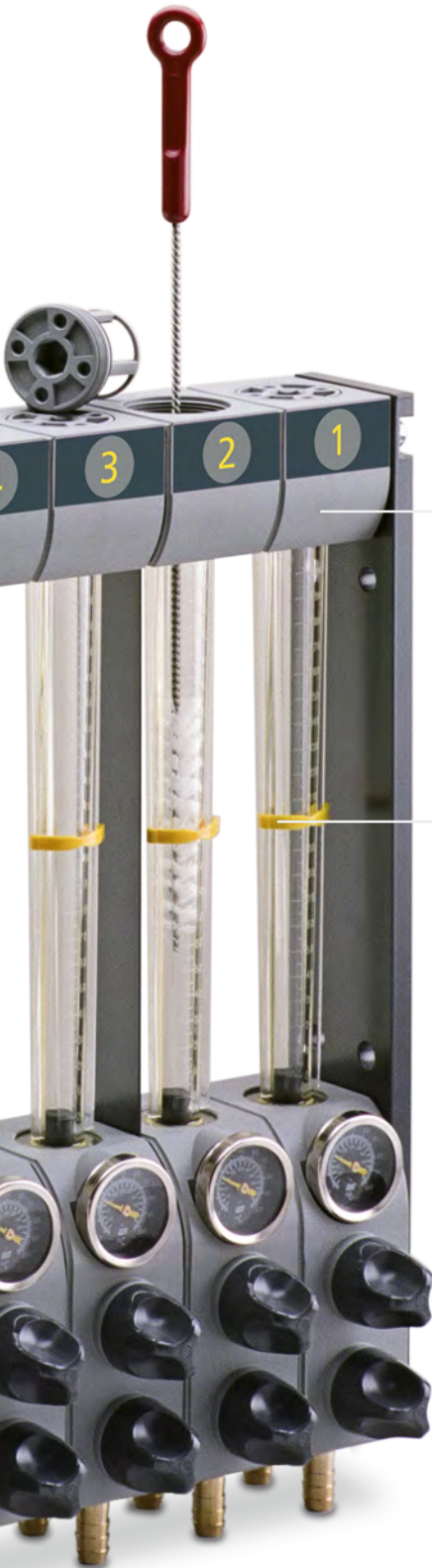

For the heavy-duty use in injection molding, a fiberglass-reinforced PPO (polypropylene oxide) compound has been chosen as the material for the top and bottom parts of the housing.

100% tightness tests and quality inspection fulfill our customers' stringent demands.

Adjustment rings to display the flow quantity.



The valve specially developed for fine adjustment of the flow quantity has been taken over from the **Flowcon plus** series. It enables precise regulation of the flow quantity in steps of one tenth of a liter.

Innovations are the double sealing of the valve disk opposite the spindle and the introduction of axial movement for the valve disk instead of radial movement. Both these innovations contribute to reduced wear of the O-rings, thus lengthening their service life. The O-rings are made of EPDM and show a high temperature stability and resistance to chemicals.

Series 110

Flow Rate 0 – 10 l/min per circuit

The essential device for your plastics processing machines for open and closed cooling circuits. Flow volume is indicated in accordance with the float measuring principle: a cone is lifted by the water flowing in the return of the mold circuit.

Technical specifications

- » Flow range per circuit: standard 0 – 10 l/min.
On request: AI, PVC-cones.
- » Standard: mold connections with 12 mm brass socket for 3/8" hoses. On request: threaded connection with G 3/8" brass threaded sleeve.
- » Option: screwed 14 mm brass socket for 1/2" hose, or screwed 20 mm brass socket for 3/4" hose.

Order data for standard model with thermometer

Order No.	
1-zone	DF01TA0000
2-zone	DF02TA0000
4-zone	DF04TA0000
6-zone	DF06TA0000
8-zone	DF08TA0000
10-zone	DF10TA0000
12-zone	DF12TA0000

Dimensions	
Circuits	Measure A mm
1-zone	72
2-zone	124
4-zone	229
6-zone	334
8-zone	439
10-zone	543
12-zone	647

Pressure max.	Temperature max.
10 bar	40 °C
8 bar	60 °C
6 bar	80 °C
4 bar	100 °C

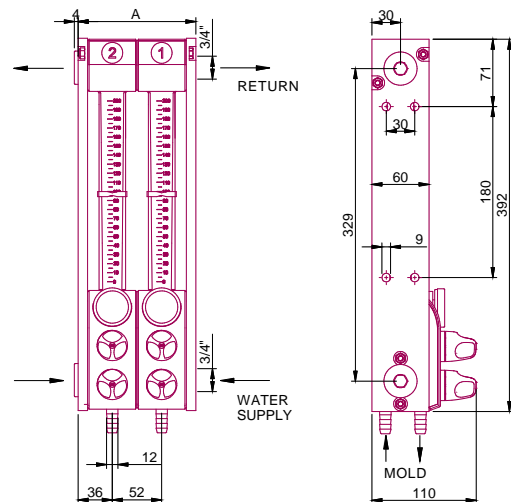

Series 310

Flow Rate 0 – 30 l/min per circuit

The optimum flow regulator for large injection molding and blow molding machines. Its low pressure drop makes it suitable for highest flow volumes. However, by means of a special design of the regulating valves, excellent regulation and accurate reproduction of cooling water volume and temperature in the different mold circuits can also be achieved for low flow volumes.

Technical specifications

- » Flow range per circuit: standard 0 – 30 l/min.
On request: Al, PVC-cones.
- » Standard: mold connections with G 3/8" brass threaded sleeve.
- » Option: with screwed 14 mm brass socket for 1/2" hose, or screwed 20 mm brass socket for 3/4" hose.

Order data for standard model with thermometer

Order No.	
1-zone	DR01TB0000
2-zone	DR02TB0000
4-zone	DR04TB0000
6-zone	DR06TB0000
8-zone	DR08TB0000
10-zone	DR10TB0000
12-zone	DR12TB0000

Dimension	
Circuits	Measure A mm
1-zone	72
2-zone	124
4-zone	229
6-zone	334
8-zone	439
10-zone	543
12-zone	647

Pressure max.	Temperature max.
10 bar	40°C
8 bar	60°C
6 bar	80°C
4 bar	100°C

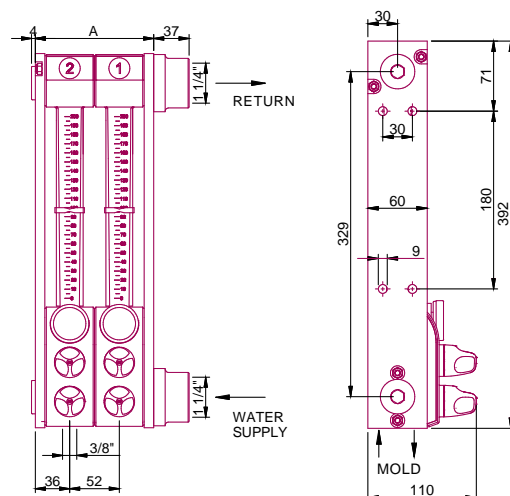

Options

Solenoid valves

The Series 110 and 310 water flow regulators can be supplied with shutdown solenoid valves and dry-out valves.

Valve Z

- » Central shutdown of several mold circuits.
- » Application: e.g. controlled by the cycle of the injection molding machine. When the injection cycle is stopped the cold water flow is shutdown to avoid condensation on the mold cavities.

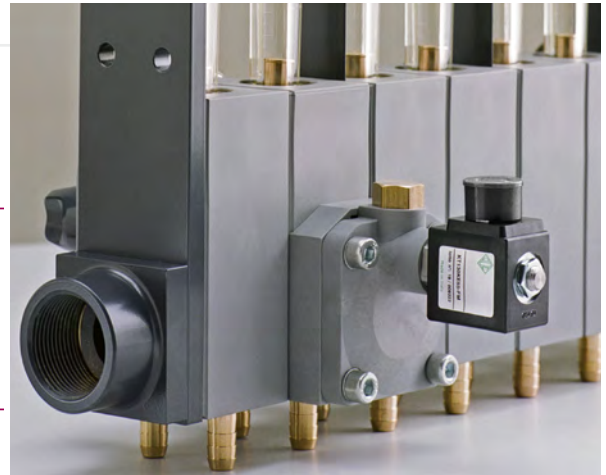
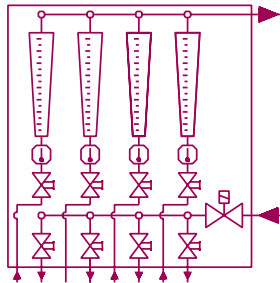

Valve E

- » Shutdown of cooling water in individual mold circuits.
- » Application: e.g. chilled cores. The valve can also be controlled by a temperature controller from the injection molding machine for mold temperature control.

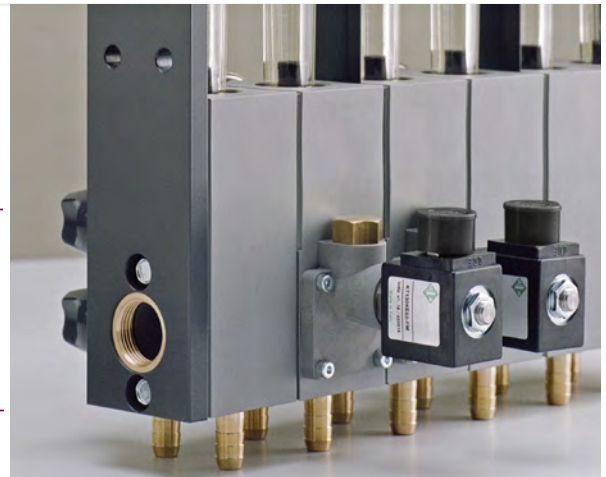
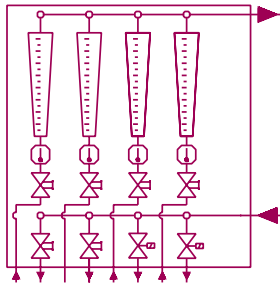

Option: Dry-out valve

- » Connection thread R 1/4" for compressed air.
- » Allows complete clean out of regulator sight glasses.



WFC Retrofitting

for the 110, 310 and 200/230 Series

wittmann



Low-cost flow control and temperature flow

With this option, existing and newly acquired WITTMANN flow controllers of the 110, 310 and 200/230 water flow controller series can be equipped with an entirely automatic control system – without circumstances.

The maximum operating temperature is 100°C (at a pressure of 4 bar).

By means of the manual control valves, the flow rate of every single circuit can be readjusted.

To each electronic unit up to 8 circuits can be connected.

Retrofitting is very simple.

Maintenance-free flow measurement unit including return flow temperature measurement.

Standard equipment

- » 7-segment display with actual value display.
- » Flow and temperature monitoring.
- » Control valves in mold forward line and return line.
- » Isolated alarm contact.

Options

- » Interface: P2 protocol, 20 mA hardware.
- » Power supply: 230 V – 50/60 Hz – 24 V.

Flow measurement vortex

- » Measurement range 1.3-20 or 2-40 l/min.
- » Measurement precision 1.5% of max. value.

WFC Retrofitting	
Operating temperature	40/60/80/100°C
Pressure	10/8/6/4 bar
Number of circuits	up to 8
Electric connection	24 V – 50/60 Hz – 0,63 A – AC/DC

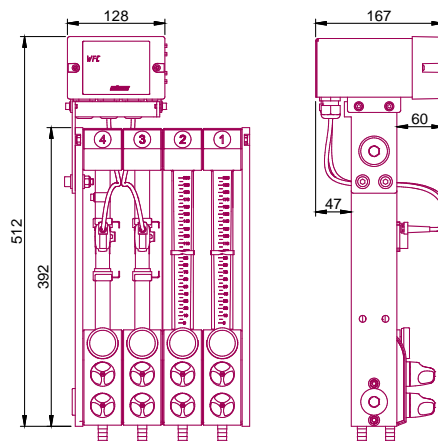

Series 200/230

Brass water flow regulator

The upper and lower blocks as well as the manifolds are made of brass for high temperatures and pressures.

Technical specifications

- » Temperature max. 100°C
- » Pressure max. 16 bar
- » Flow range per circuit
 - Series 200** 0 - 10 l/min
 - Series 230** 0 - 30 l/min
 - On request: AI, PVC-cones.
- » Standard: mold connections with G 3/8" brass threaded sleeve.
On request: with screwed 14 mm brass socket for 1/2" hose, or screwed 20 mm brass socket for 3/4" hose.

Order data for standard model with thermometer

Circuits	Order No.	
	Series 200	Series 230
2-zone	DH02TB0000	DQ02TB0000
4-zone	DH04TB0000	DQ04TB0000
6-zone	DH06TB0000	DQ06TB0000
8-zone	DH08TB0000	DQ08TB0000
10-zone	DH10TB0000	DQ10TB0000
12-zone	DH12TB0000	DQ12TB0000

Series 200/230	
Circuits	Measure A mm
2-zone	140
4-zone	262
6-zone	384
8-zone	506
10-zone	628
12-zone	750

Series 200/230	
Pressure max.	Temperature max.
16 bar	20°C
10 bar	40°C
8 bar	60°C
6 bar	80°C
4 bar	100°C

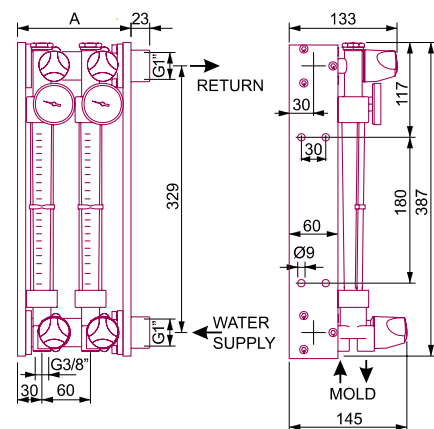

Series 401

Flow Rate 0 – 8 l/min per circuit

The ideal unit specially designed for the smaller range of injection molding machines up to approx. 80 tons clamping force.

Technical specifications

- » Flow range per circuit: standard 0 – 8 l/min.
On request: AI, PVC-cones.
- » Standard: mold connections with 12 mm brass socket for 3/8" hose.

Order data for standard model with thermometer

Order No.	
2-zone	DD02TA0000
4-zone	DD04TA0000
6-zone	DD06TA0000
8-zone	DD08TA0000

Series 401	
Kreise	Measure A mm
2-zone	110
4-zone	200
6-zone	290
8-zone	380

Series 401	
Pressure max.	Temperature max.
10 bar	40°C
8 bar	60°C
6 bar	80°C
4 bar	100°C

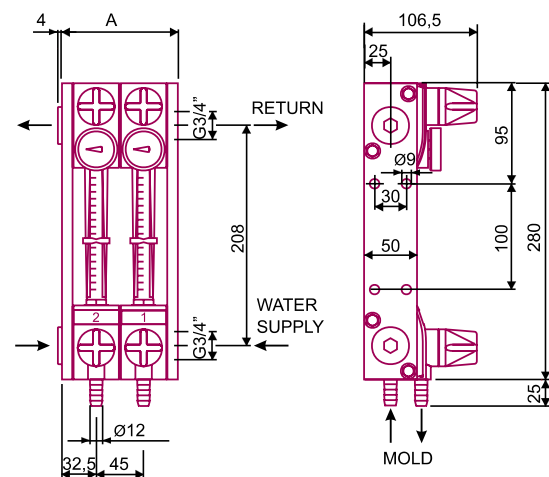

The Wittmann logo is a stylized, italicized wordmark in a dark red color, set against a white background that is part of a red parallelogram shape.

WITTMANN Technology GmbH

Lichtblaustrasse 10

1220 Vienna | Austria

Tel.: +43 1 250 39-0

info.at@wittmann-group.com

www.wittmann-group.com