

VM R 40 – 300 t

VM 60 – 200 t

CM 40 – 80 t

CM R 40 – 80 t

CM S 40 – 80 t

Flexible, automated production

world of innovation



VM AND CM SERIES

The basis for your success

The vertical machines of the VM and CM series are both available in a rotary table version, the CM series can also be supplied with a sliding table. The vertical-machine series with clamping force sizes from 40 to 300 t, equipped with the high-performance Unilog B8 control system and rotary tables ranging from 752 mm to 1755 mm in diameter, represents a benchmark in flexible parts production. It offers first-class precision and quality assurance and can be extended with automation concepts and a wide range of options. The rotary table machine is ideally suited for handling complex requirement profiles, special functions and processes, and for processing special materials as well.



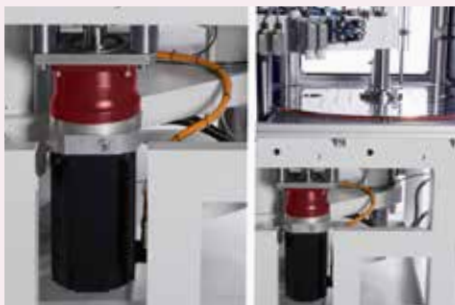

VM and CM series

The system highlights

- » **Light curtain**
Safety of the parts insertion and removal area is ensured by means of light curtains as standard. This gives the machine operator optimal access for parts removal and also ideal conditions for further automation concepts.
- » **Media distributor oscillating operation**
The supply of media to the molds in 2-station rotary table machines is handled by an easily accessible media distributor offering a high degree of flexibility in the number of cooling and tempering circuits, hydraulic circuits for core pulls, the pneumatic system, mold heating and additional electrical signals.
- » **Media distributor rotary operation**
Rotary manifolds distributing various media are available for 3- and 4-station rotary table machines. This type of media distributor offers numerous adjustment options for the hydraulic and pneumatic systems and air supply connections.
- » **Servo-electric rotary plate**
The drive of the rotary plate is equipped with a speed-controlled servo motor, which enables extremely fast and precise rotary motion as well as an exact positioning.
- » **Energy-saving hydraulic system**
The machine's flexible drive concept, based on the "Drive-on-Demand" system, allows short machine cycle times and parallel movements of ejector and core pulls as part of the VM R standard equipment package.

VM SERIES

Universal precision

Special features

» Convertible injection units

Injection units with a uniform 22:1 L/D ratio, up to 3000 bar injection pressure and increased injection and plasticizing performance offer additional scope for the production of injection-molded parts. The injection unit can be arranged vertically (alternating or parallel in 2c operation) or horizontally. Optionally, a version with servo-electric injection unit is also available.

» Clamping system

4 symmetrically arranged clamping cylinders ensure fast, evenly distributed clamping force build-up as well as a compact design. A low working height with optimal access to the central ejector provides ergonomic working conditions in semiautomatic operation.

» Hydraulic systems

The machine's flexible drive concept, based on the "Drive-on-Demand" system, allows short machine cycle times.



VM R

- » Symmetrical 3-point force transmission with below positioned clamping cylinders ensure optimal force distribution in the mold.
- » Exact platen parallelism across the entire stroke
- » Fully hydraulic clamping concept
- » High opening and closing speeds thanks to differential control system and interconnection of both pumps
- » Short dry cycle times
- » High repeatability of all parameters
- » Ergonomic working height for the operator
- » Easy access to mold space and nozzle
- » Sensitive mold safety system
- » Extensive choice of rotary table diameters
- » Fully controlled servo-rotary table drive with precise positioning
- » Flexible configuration of rotary table stations
- » Low-maintenance and service-friendly design of all components
- » Rotary table running on sliding plates made of bronze with graphite inclusions

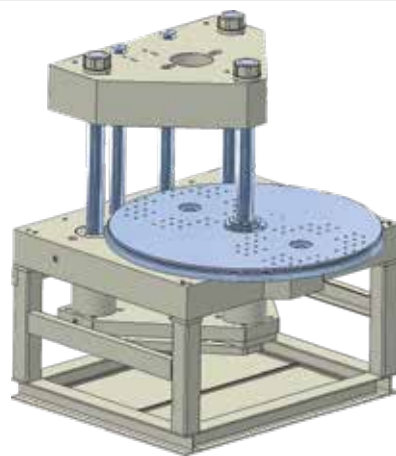

VM

- » Symmetrical 4-point force transmission with below positioned clamping cylinders ensure optimal force distribution in the mold.
- » Exact platen parallelism across the entire stroke
- » Fully hydraulic clamping concept
- » High opening and closing speeds thanks to differential control system and interconnection of both pumps
- » Short dry cycle times
- » High repeatability of all parameters
- » Ergonomic working height for the operator
- » Easy access to mold space and nozzle
- » Sensitive mold safety system

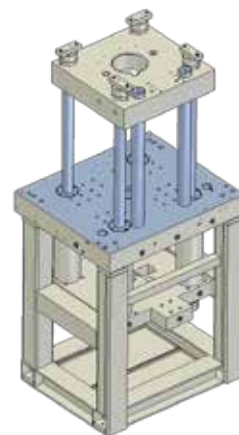

CM SERIES

For maximum mold space

Special features

» Injection units

Servo valve controlled, vertical injection units from the PowerSeries to process TPE and various conventional thermoplastic resins.

» Machine concept

Compact design with small footprint for space saving production.

» C-frame

Vertical clamping unit in C-frame design with two symmetrical clamping cylinders. Maximum mold space with optimal accessibility.

» Ergonomic workstation

Reduced working height of just 1000 mm for ergonomic working conditions in semi-automatic operation.



CM

- » Vertical clamping unit without tie bars
- » Symmetrical 2-point force transmission by means of clamping cylinders mounted above
- » Exact platen parallelism across the entire stroke through support via linear guides
- » Fully hydraulic clamping concept
- » High opening and closing speeds thanks to differential control system and interconnection of both pumps
- » Short dry cycle times
- » High repeatability of all parameters
- » Ergonomic working height for the operator
- » Easy access to mold space and nozzle
- » Sensitive mold safety system

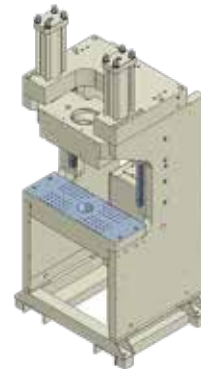

CM R

- » Vertical clamping unit without tie bars
- » Symmetrical 2-point force transmission by means of clamping cylinders mounted above
- » Exact platen parallelism across the entire stroke through support via linear guides
- » Fully hydraulic clamping concept
- » High opening and closing speeds thanks to differential control system and interconnection of both pumps
- » Short dry cycle times
- » High repeatability of all parameters
- » Easy access to mold space and nozzle
- » Fully controlled servo-rotary table drive with precise positioning
- » Flexible configuration of rotary table stations
- » Low-maintenance and service-friendly design of all components
- » Rotary table running on sliding plates made of bronze with graphite inclusions

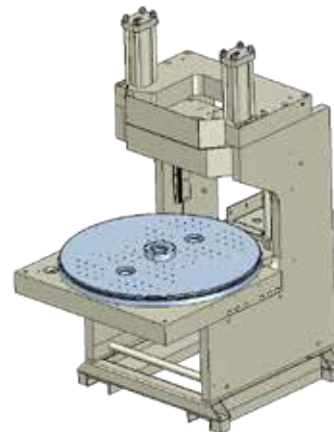

CM S

- » Vertical clamping unit without tie bars
- » Symmetrical 2-point force transmission by means of clamping cylinders mounted above
- » Exact platen parallelism across the entire stroke through support via linear guides
- » Fully hydraulic clamping concept
- » High repeatability of all parameters
- » Fully controlled servo-sliding table drive with precise positioning
- » Sliding table running on sliding plates made of bronze with graphite inclusions
- » Pinion and rack hardened

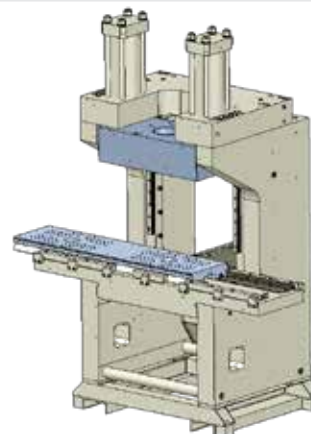

INJECTION UNIT

Versatile precision

» Convertible injection units

Injection units with a uniform 22:1 L/D ratio, up to 3000 bar injection pressure and increased injection and plasticizing performance offer additional scope for the production of injection-molded parts. The injection unit can be arranged vertically (alternating or parallel in 2c operation) or horizontally. Optionally, a version with servo-electric injection unit is also available.

» A concept for improved parts quality

- Optimized melt homogeneity thanks to a uniform L/D ratio
- Linear guide systems ensure precise axial movements of the injection unit.
- Carriage cylinders positioned opposite each other provide momentum-free nozzle carriage.

» Ultimate precision and repeatability

- Compact design with integrated hydraulic block and easy access to all components
- Direct screw drive via low-speed hydraulic motor with optimal adaptation to individual plasticizing demands
- Ultimate repeatability thanks to a controlled servo-valve

» Injection units for more flexibility

- Injection unit also available in electric design
- Short footprint with two pulling cylinders
- Universal compatibility of barrels with different injection units
- High injection rates



Anti-wear options

In addition to the premium-quality standard equipment, an extensive range of options is available to provide extra anti-wear and/or anti-corrosion protection. Predefined option packages and a selection matrix facilitate the selection of the right plasticizing unit.



SERVO-DRIVE TECHNOLOGY

High energy efficiency

Wittmann

Servo-electric injection unit

Option

- » **Everything to ensure series consistency**
 - Plasticizing parallel to clamping unit movements and start of the injection process during clamping force build-up are possible as standard.
 - Injection units with a higher injection performance can be supplied as an option.
 - Moment-free nozzle contact thanks to axial configuration of traveling cylinders
 - Plasticizing units can be mounted to different injection aggregates with identical screw diameters.
- » **Optimal operational excellence**
 - The complete range of all-electric injection units is designed for quick barrel exchange from above.
 - Easy access for changeover work thanks to compact design and sliding guard
- » **More productivity and efficiency**
 - High-resolution absolute value encoder for precise control
 - Low-noise injection spindle with modern ball screw drive and low grease consumption

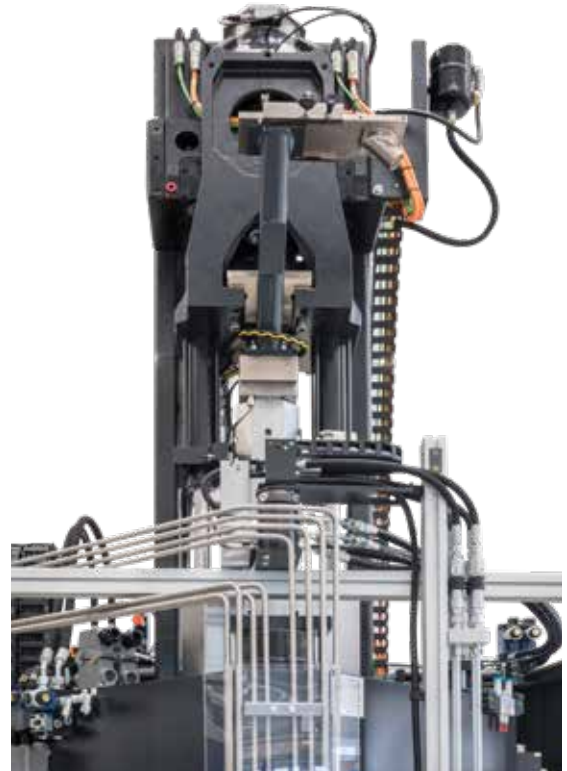

Servo-hydraulic drive

Fast responding, precise, thrifty

The „Drive-on-Demand“ system is available to reduce energy consumption. The servo-hydraulic drive is an innovative combination of a fast-responding, speed-controlled, air-cooled servo motor with a fixed displacement pump. This drive unit is only activated when required by movements and pressure build-up. During cooling times or cycle pauses for parts handling, the servo drive remains switched off and thus consumes no energy. In operation, „Drive-on-Demand“ is the basis for highly dynamic, controlled machine movements and short cycle times.

The „Drive-on-Demand“ system is standard in the CM series (option in VM series).

UNILOG B8

Complex matters simplified

The Unilog B8 machine control system is the WITTMANN BATTENFELD solution to facilitate the operation of complex processes for human operators. For this purpose, the integrated industrial PC has been equipped with an enlarged intuitive touch screen operator terminal. The visualization screen is the interface to the new Windows® 10 IoT operating system, which offers extensive process control functions. Next to the pivotable monitor screen, a connected panel/handset is mounted on the machine's central console.



Unilog B8 Highlights

- » **Operating logic**
with a high degree of self-explanation, similar to modern communication devices
- » **2 major operating principles**
 - Operating/movement functions via tactile keys
 - Process functions on touch screen (access via RFID, key card or key ring)
- » **Process visualization**
via 21.5" touch screen display (full HD), pivoting laterally
- » **New screen functions**
 - Uniform layout for all WITTMANN appliances
 - Recognition of gestures (wiping and zooming by finger movements)
 - Container function – split screen for sub-functions and programs
- » **Status visualization**
uniform signaling system across the entire WITTMANN Group
 - Headline on the screen with colored status bars and pop-up menus
 - AmbiLED display on machine
- » **Operator assistance**
 - QuickSetup: process parameter setting assistant using an integrated material database and a simple query system to retrieve molded part data with machine settings pre-selection
 - Extensive help library integrated

The process in constant view

Wittmann

» SmartEdit

SmartEdit is a visual, icon-based cycle sequence programming facility, which enables direct addition of special functions (core pulls, air valves, etc.) based on a standard process via touch operation on the screen. In this way, a total user-defined sequence can be compiled from a sequence menu. This machine cycle, visualized either horizontally or vertically, can be adjusted simply and flexibly to the process requirements by finger touch with "drag & drop" movements.

The advantages

- Icon visualization ensures clarity.
- Clear events sequence through node diagram
- Alterations without consequences through "dry test runs"
- Theoretical process sequence can be quickly implemented in practice.
- Automatic calculation of the automation sequence based on the actual set-up data set without machine movements

» SmartScreen

- Partitioning of screen displays to visualize and operate two different functions simultaneously (e.g. machines and auxiliaries)
- Uniform design of the screen pages within the WITTMANN Group
- Max. 3 containers can be addressed simultaneously for the SmartScreen function.
- Adjustments of set values can be effected directly in the set value profile.

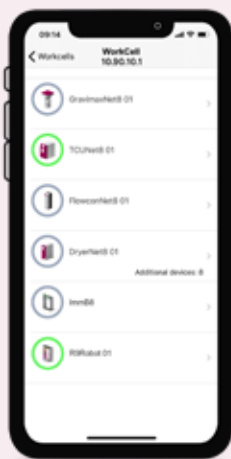
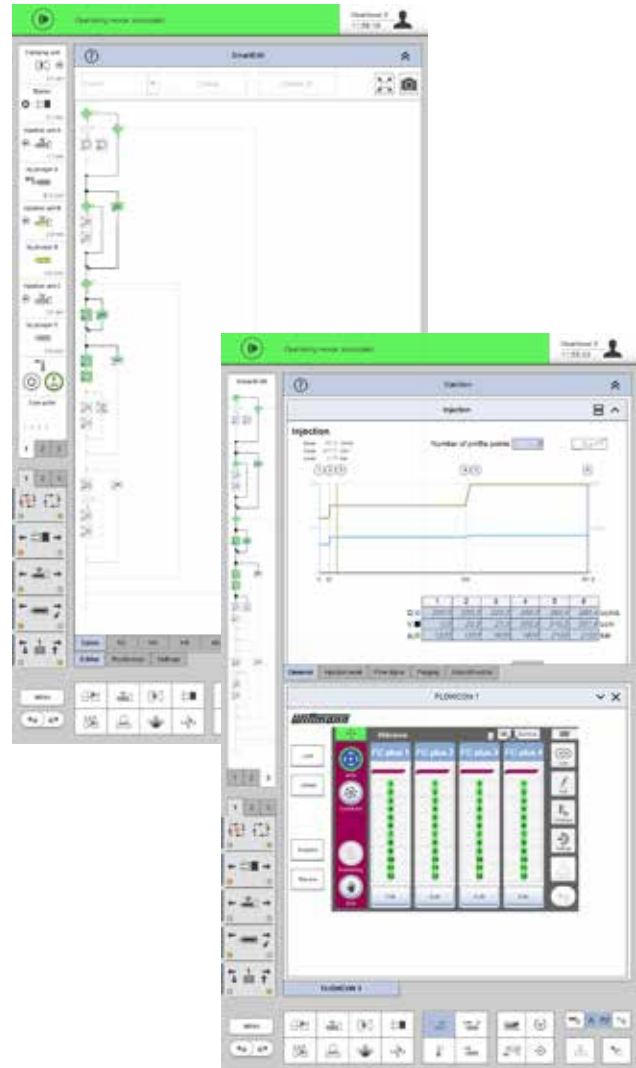

Remote communication

» QuickLook 4.0

Production status check via smartphone – simple and comfortable:

- Production data and statuses of all essential appliances in a production cell
- Complete overview of the most important production parameters
- Access to production data, error signals and user-defined data
- The production cell overview offers a clear, simple overview of the production cell's general condition and that of its individual Wittmann 4.0 appliances.

» Global online service network

- Web-Service 24/7: direct Internet connection to WITTMANN BATTENFELD service
- Web-Training: efficient staff training by means of the virtual training center

WITTMANN 4.0

Communication in and with production cells

With its communication standard Wittmann 4.0, the WITTMANN Group offers a uniform data transfer platform between injection molding machines and auxiliary equipment from WITTMANN. In case of an appliance change, the corresponding visualizations and settings are loaded automatically via an update function, following the principle of "Plug & Produce".

Connection of auxiliaries via Wittmann 4.0

- » **WITTMANN Flowcon plus water flow regulator, Gravimax blenders and Aton dryers**
 - Units directly addressed and controlled via the machine's control system
 - Joint saving of data in the production cell, the machine and in the network via MES
- » **WITTMANN robots with R9 control system**
 - Operation of robots via the machine's monitor screen
 - High-speed communication between machine and robot to synchronize movements
 - Important machine movements can be set via the R9 robot control system
- » **WITTMANN Tempro plus D temperature controllers**
 - Setting and control of temperatures via the machine's control system possible
 - All functions can be operated either on the unit or via the machine's control system

Integration in MES system

The integration of machines and complete production cells in an MES system is a prerequisite for an efficient and transparent production facility according to the Industry 4.0 concept.

Depending on customers' requirements, small and medium-sized companies as well as global players are offered a compact MES solution based on TEMI+. Due to the Windows® 10 IoT operating system, it is also possible to have selected status information from all connected machines on the production floor shown under Smart-Monitoring on the display screen of every machine.

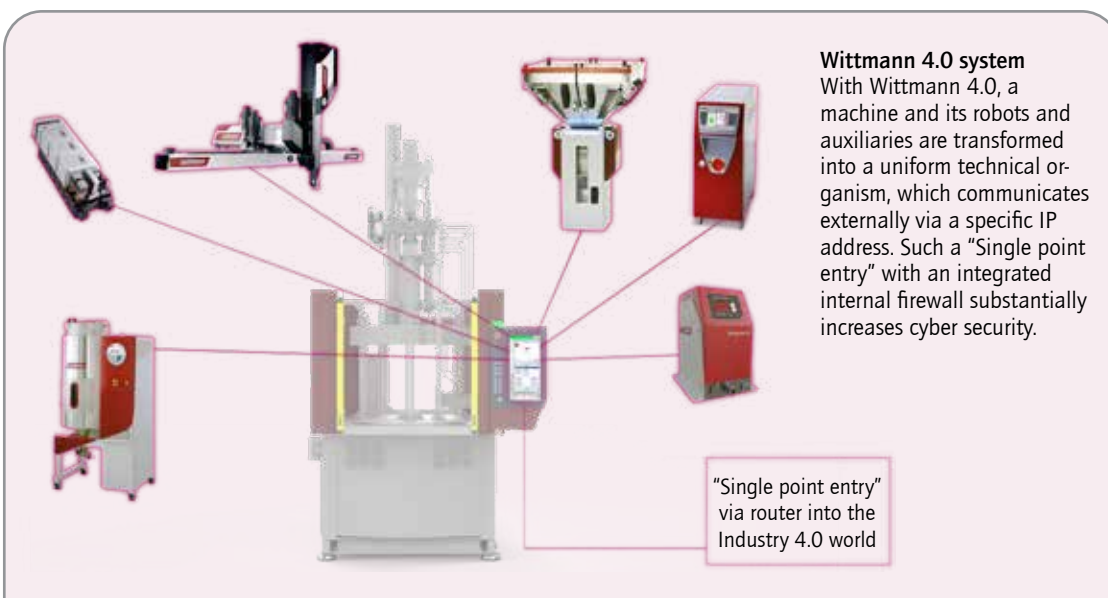
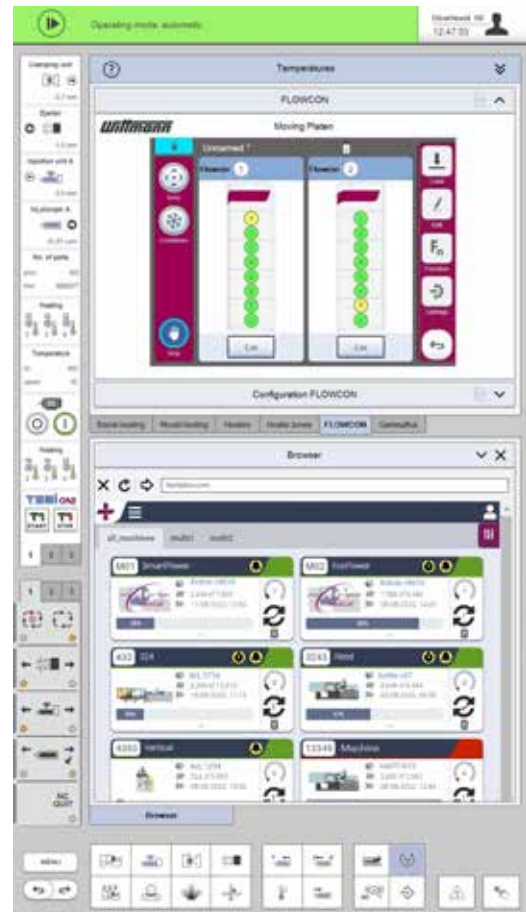

Wittmann 4.0 system

With Wittmann 4.0, a machine and its robots and auxiliaries are transformed into a uniform technical organism, which communicates externally via a specific IP address. Such a "Single point entry" with an integrated internal firewall substantially increases cyber security.

"Single point entry" via router into the Industry 4.0 world

TECHNICAL DATA

VM R, VM

Wilmann



COMBINATIONS VM R

Clamping unit	Rotary table	Injection unit							
		60	130	210	350	525	750	1000	1330
t	mm								
VM R 40	752	•	•						
VM R 60	1040	•	•	•	•				
VM R 75	1040		•	•	•	•			
VM R 110	1280		•	•	•	•			
VM R 150	1280				•	•	•	•	
VM R 150	1520				•	•	•	•	
VM R 200	1520					•	•	•	
VM R 200	1755					•	•	•	
VM R 270	1755					•	•	•	•
VM R 300	1755					•	•	•	•

COMBINATIONS VM

Clamping unit	Injection unit						
	60	130	210	350	525	750	1000
t							
VM 60	•	•	•	•			
VM 80		•	•	•	•		
VM 100		•	•	•	•		
VM 150				•	•	•	•
VM 200					•	•	•

Material	Factor
ABS	0.88
CA	1.02
CAB	0.97
PA	0.91
PC	0.97
PE	0.71
PMMA	0.94
POM	1.15
PP	0.73

The maximum shotweights (g) are calculated by multiplying the theoretical shot volume (cm³) by the above factor.

Material	Factor
PP + 20 % Talc	0.85
PP + 40 % Talc	0.98
PP + 20 % GF	0.85
PS	0.91
PVC hard	1.12
PVC soft	1.02
SAN	0.88
SB	0.88
PF	1.3
UP	1.6

Dark grey boxes = thermosets



COMBINATIONS CM							
Clamping unit	Injection unit						
t	60	130	210	350	525	750	1000
CM 40	•	•	•	•			
CM 80		•	•	•	•	•	

COMBINATIONS CM R							
Clamping unit	Rotary table	Injection unit					
t	mm	60	130	210	350	525	750
CM R 40	752	•	•	•	•		
CM R 40	1280	•	•	•	•		
CM R 80	1520		•	•	•	•	•

COMBINATIONS CM S							
Clamping unit	Injection unit						
t	60	130	210	350	525	750	1000
CM S 40	•	•	•	•			
CM S 80		•	•	•	•	•	

Material	Factor
ABS	0.88
CA	1.02
CAB	0.97
PA	0.91
PC	0.97
PE	0.71
PMMA	0.94
POM	1.15
PP	0.73

The maximum shotweights (g) are calculated by multiplying the theoretical shot volume (cm³) by the above factor.

Material	Factor
PP + 20 % Talc	0.85
PP + 40 % Talc	0.98
PP + 20 % GF	0.85
PS	0.91
PVC hard	1.12
PVC soft	1.02
SAN	0.88
SB	0.88
PF	1.3
UP	1.6

Dark grey boxes = thermosets

STANDARD

- Standard
- Option
- not available

	VMR CMR	VM CM, CMS
Hydraulics		
Speed-controlled servo motor for hydr. pump	•	• -
Oil filtration by fine flow filter with electr. clogging indicator	•	•
Oil level indicator with alarm	•	•
Closed-loop oil temperature control with oil pre-heating	•	•
Oil temperature monitoring	•	•
Oil tank with connections for external oil filtration	•	•
Separate hand keys for core pulls	•	•
Display of actual pump system pressure via touch screen	•	•
Clamping unit		
Clamping force adjustable via touch screen	•	•
Closing and opening speed adjustable	•	•
Closing and opening force adjustable	•	•
Mold safety program	•	•
Bolt pattern and mold centering via EUROMAP	•	•
Hydraulic mold close inhibit, electr. monitored	•	•
Mechanical mold safety mechanism for vertical clamp incl. electr. supervision	•	•
Hydraulic ejector in operating position, several ejector programs, multiple strokes and parallel movements during machine cycle	•	-
Rotary table with 2 stations, oscillating 180°	•	-
Hardened rotary table gear ring	•	-
Mechanical indexation for final positioning of rotary table	•	-
Rotary table covered by stainless steel	•	-
Rotary table on sliding plates: bronze with graphite inclusions	•	-
Central lubrication for rotary table: sliding plates and gear ring	•	-
Rotary table speed adjustable via touch screen	•	-
Rotary table position visualization via touch screen	•	-
Pre-sel. of activ mold lower parts (1 or 2) for prod. process	•	-
Servo-electrical rotary drive	•	-
Injection unit		
Screw L/D = 22 with check valve, screw and barrel nitrated	•	•
Thermocouple failure monitor	•	•
Maximum temperature supervision	•	•
Pluggable cylinder heater bands and thermocouple	•	•
Temperature control of feed throat integrated	•	•
Open nozzle	•	•
Relief valve for nozzle pressure control	•	•
Injection unit mounted either in horizontal or vertical position (except CM)	•	•
Purge guard	•	•
Hopper MH 206 WITTMANN	•	•
Selectable barrel stand-by temperature	•	•
Physical units – bar, ccm, mm/s etc.	•	•
Screw protection	•	•
Linear bearings for the injection unit	•	•
Adjustable height (of horizontal injection unit only)	•	•
Safety gate		
Safety gate left, right and behind clamp unit with electr. and hydr. monitoring, CE	•	•
Infrared light curtain in operating station	•	•
Cooling/conditioning		
2 cooling water circuits up to 120 °C on rotary table via medium distributor (oscil. operation)	•	-

	VMR CMR	VM CM, CMS
Electrical components/Control system		
Control zone for nozzle heater band 230 V	•	•
Fuse protection for sockets	•	•
Switch cabinet cooling – circulation fan for environment temperature to 30 °C	•	•
Emergency stop switch button	•	•
Printer socket	•	•
USB – 1 x operating unit	•	•
1 Ethernet interface (switch cabinet)	•	•
Printer via USB connection or network	•	•
Control system Unilog B8 – 21,5" multi-touch screen (full HD)	•	•
Control panel with selectable haptic keys	•	•
Software for operating hours counter	•	•
Closing/Opening – 5 profile steps	•	•
Ejection forward/back – 3 profile steps	•	•
Nozzle forward/back – 3 profile steps	•	•
Injection/Holding pressure – 10 profile steps	•	•
Screw speed/Back pressure – 6 profile steps	•	•
Parts counter with good/bad part evaluation	•	•
Purging program through open mold (only with 2-station VM R machines activated in standard)	•	•
Stroke zero offset settings	•	•
Start-up program	•	•
Switchover to holding pressure MASTER/SLAVE by injection time, screw stroke/injection volume and injection pressure	•	•
Self-teaching temperature controller	•	•
Display of temperature inside electrical cabinet	•	•
Seven-day timer	•	•
Access authorization via USB interface, password system and RFID authorization system (1 x check card IT-level-15, 1 x token customer level-30 and 1 x token customer service level-20 are included in delivery)	•	•
Freely configurable status bar	•	•
Physical, process-related units	•	•
Automatic dimming	•	•
Logbook with filter function	•	•
User programming system (APS)	•	•
Userpage	•	•
Note pad function	•	•
Cycle time analysis	•	•
Hardcopy function	•	•
Internal data storage via USB connection or network	•	•
Online language selection	•	•
Online selection of imperial or metric units	•	•
Time monitoring	•	•
Basic Quality Monitoring (1 freely configurable network connection, quality table with 1000 storage depth, events protocol (logbook) for 1000 events, actual value graphics with 5 curves, 1 envelope curves monitoring)	•	•
Injection integral supervision	•	•
Metering integral supervision	•	•
Alarm message via e-mail	•	•
SmartEdit – sequence editor	•	-
QuickSetup – assistance program for initial parameter setting	•	-
Accessories		
Paint RAL 7047 telegrey 4/RAL 3004 crimson	•	•

Hydraulics	VMR CMR	VM CM, CMS
Extra large oil cooler	•	•
Core pull movement and parallel ejection with double pump	•	•
Core pull movement and parallel ejection incl. fast injection with double pump	•	•
Hydraulic core pull	•	•
Pneumatic core pull	•	•
Pneum. hydraul. block for mold shut-off nozzle control	•	•
Core pull pressure release functions	•	•
Filter in water inlet of oil cooler	•	•
Adapter with ball valve on the oil tank for oil maintenance	•	•
Separate bypass filtration unit	•	•

Clamping unit		
Non-standard mold height as per customer request	•	•
Non-standard opening stroke as per customer request	•	•
Non-standard layout of fastening bores in platen	•	•
T-slots in mold platen	-	•
Cooling of moving and fixed platen	•	•
SPI mold centering and bolt pattern	•	•
Ejector cross as per EUROMAP/SPI	•	•
Increased ejector force	•	•
Ejector platen safety device	•	•
Double check valve to keep ejector in end-position	•	•
Ejector location choosable with 3 and 4 stationed machines	•	-
Mechanical ejector couple	•	•
Ejector back via 2-hand operation with activated safety device	•	•
Air valve, activated travel- and time-dependent	•	•
Rotary table with 3 stat., 120°; 4 stat., 90°; servo motor	•	-
Quick clamping system, hydr. or mechanical	•	•

Injection unit		
Add. injection unit (V/H) plugable	• -	• -
Prep. for mount. a 2 nd plugable injection unit, for altern. use	•	•
High revolution screw motor	•	•
Adjust. height of horiz. injection unit incl. stroke measur. device	•	•
Grooves in the feeding zone	•	•
High torque screw motor in lieu of standard	•	•
High temperature heater bands 450 °C	•	•
Screw drive by a.c. servo motor	•	•
Ball type screw tip (from Ø 30 mm)	•	•
Needle type shutoff nozzle spring, pneum. or hydr. operated	•	•
Melt temperature or pressure sensor in cylinder head	•	•
Open Airmould nozzle, pressure controlled	•	•
Barrel isolation	•	•
Pneum. purging guard for horizontal injection units	• -	• -
Pneum. purging tray for vertical injection units	•	•
Wear resistant screw and barrel AK+	•	•
Screw with mixing section or barrier section	•	•
Application package processing thermosets	•	•
Application package processing liquid silicone rubber (LSR)	•	•
Application package processing PIM (MIM/CIM)	•	•
2-component meter mix pump	•	•
Vacuum pump	•	•
Magnet in material hopper	•	•
Hopper loader UNIFEED A1 in lieu of material hopper	•	•
Closed injection loop controlled via servo valve	•	•
29 liter stainless steel hopper, can be shut and emptied	•	•

Safety gate	VMR CMR	VM CM, CMS
Add. operation station incl. infrared curtain and a small manual desk (cycle start and emergency stop)	•	-
Extended execution for manual part removal	•	•
Clamping unit protected by add. light curtain	•	-
Pneum. safety gate at the operator side	•	•
Preparation for add. automation systems incl. safety related interfaces	•	•
Complete covering for horizontal injection unit	•	•

Cooling/conditioning		
Cooling water battery with temperature gauges	•	•
Shut-off valve for cooling water battery	•	•
Venting valve for cooling water battery	•	•
Filter in water inlet of cooling circuit	•	•
Hosting of cooling circuits on fixed and moving nozzle platen	•	•
Rotary distributor for condit., hydr., pneum., electr. circuits	•	-

Electrical components/Control system		
Clamp force display and supervision	•	•
Temperature control zone for hot runner	•	•
Non-contact stroke transducers	•	•
Special voltage	•	•
Control cabinet cooler	•	•
Closed-loop temperature control of platen and mold	•	•
Additional socket	•	•
Interface for handling equipment	•	•
Energy consumption analysis	•	•
Interface for RJG-Insight system	•	•
Switch over to holding pressure by cavity or melt pressure	•	•
Switch over to holding pressure by external signal	•	•
Cavity pressure/cavity surface temperature display	•	•
Injection compression program/venting program	•	•
Melt cushion control	•	•
Audible alarm	•	•
Temperature control interface digital, serial 20 mA TTY protocol	•	•
CAN-Bus-interface for temperature controller EUROMAP 66-2	•	•
Interface for extended mold supervision on upper mold and lower mold	•	•
Mobile Airmould interface	•	•
Interface for robots as per EUROMAP 67	-	•
Interface for robots as per EUROMAP 67.1	•	-
Host computer interface/PDA as per EUROMAP 63	•	•
Potential-free contact parallel to plasticizing	•	•
Machine fault (potential-free contact)	•	•
BNC-connectors for injection process analysis	•	•
Interface for full integration of robot	•	•
Interface for brushing device	•	•
Interface for vacuum pump	•	•
Injection parameter switchover during starting phase	•	•
Web- and remote-service	•	•
SmartMonitoring MES software packages	•	•
HiQ packages	•	•
Integration package Wittmann 4.0	•	•

Accessories		
Lighting in mold space and tool kit	•	•
Special paint/touch-up kit	•	•
Webcam	•	•
Leveling elements	•	•

The Wittmann logo is located in the bottom right corner of the page. It consists of the word "Wittmann" in a white, italicized, sans-serif font, set against a dark red, rounded rectangular background.

WITTMANN BATTENFELD GmbH

Wiener Neustädter Strasse 81

2542 Kottlingbrunn | Austria

Tel.: +43 2252 404-0

info@wittmann-group.com

www.wittmann-group.com