



NEWS RELEASE
[Witt-NR-02-2022_K-Show]

August 24, 2022

WITTMANN presents innovations at the K 2022

The WITTMANN Group takes this year's K in Düsseldorf as an opportunity to present its latest developments in a wide range of different areas. From 19 to 26 October, WITTMANN Technology will showcase its current innovations across the entire product range at booth No. F23 in hall 12.

WX128 robots: the new small appliance series

The WITTMANN palletizing solution and the **Sonic 143** chess application to be shown at the K 2022 are largely based on robot systems already on the market. In addition, the latest model of the **WX** robot series from WITTMANN, the **WX128**, will be introduced at the K; it is destined to become the successor of the **W818** and **W918** robots, which have already been very successful for a number of years.

The WITTMANN robots of the **W818 / W918** series have been in use on injection molding machines with clamping forces ranging from 80 to 200 t for several decades. More than 18,000 units of this type with various control systems have been manufactured so far. So, the **WX128** will be following in large footsteps. To enable it to meet such expectations, WITTMANN's product developers have come up with several good ideas.

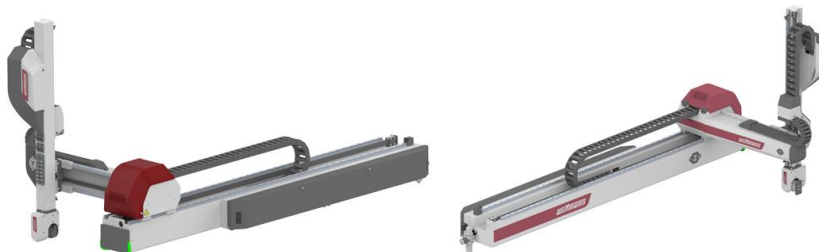

*Views of the new, compact WX128 robot
from WITTMANN with A-C servo axis.*

The **WX128** benefits from the experience made with the larger **WX138** model already available on the market. Even at first glance, the **WX128** convinces prospective buyers by its newly developed compact control cabinet on the horizontal Z axis. To create this part, the rear structure has been shortened by 30%. Especially for small

injection molding machines, it has now become possible to design an extremely compact protective housing, largely by way of positioning the drive unit and connection cables on the inside. The WITTMANN **WX128** relies on a proven belt drive concept on all linear main axes. One decisive argument here was high dynamism – for instance the vertical axis can accelerate at roughly four times the gravitational acceleration rate. Additional reasons were minimal sound emission and easy maintenance. The predecessor model of the **WX128** still was equipped with an external rack on the demolding X axis.

Some main objectives of the development work were to create an easily accessible, low-maintenance design and to meet the demand for flexible upgradeability. As a result, it has become possible to equip the **WX128** with up to two additional rotational servo axes. This extension can be implemented either at once or as a retrofit later on without having to make any alterations to the control cabinet, which could involve having to modify the protective housing as well. At the K 2022, WITTMANN is presenting the **WX128** robot with an A-C servo axis equipped with an illuminated gripper.

The new **WX128** with a nominal load capacity of 6 kg, and offered exclusively with the current WITTMANN **R9** control system, will be available from the end of 2022. Based on the appliance exhibited at the K 2022, some further models will be added to the WITTMANN range from 2023 onwards.

Robot palletizing solution

One of the new robot applications WITTMANN will present at the K 2022 is the WITTMANN palletizing cell. This application handles automatic loading and unloading of transport systems.

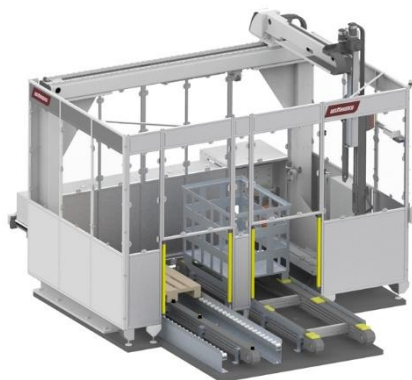

The WITTMANN W938T robot operates inside the palletizing cell.

In this exemplary application, stacks of trays [1 tray = 360 × 270 × 75 mm] are transported by a horizontal servo axis from a buffer behind the palletizing cell to the workspace of the top entry robot. A newly developed **W938T** robot with an upstream demolding axis and a B servo rotation axis (rotating around the vertical axis) takes over the trays. Before these are stacked on a Euro pallet [1,200 × 800 mm] or in a

DB mesh box [1,240 × 835 × 970 mm] their orientation is checked by visual inspection. Then they are positioned on the transport container according to the instructions issued by the depositing program. As a further step, this cell is used to demonstrate how two materials handling systems supplied by ErgoTek move the full pallet or mesh box into and out of the protective housing. The outlets of the protective housing are secured by light grids and muting.

All components supplied by ErgoTek are controlled exclusively via the robot's WITTMANN **R9** control system. This palletizing cell impressively demonstrates the extremely flexible application possibilities of a Cartesian robot. The concept shown can be used at the end of production chains with several injection molding machines or as a stand-alone solution in warehouse logistics at a distance from plastics production. The **W938T** robot shown in this configuration has a maximum load capacity of 15 kg. The interface connection to the materials handling system can be either – quite traditionally – a company employee with a pallet truck, or a semi or fully automatic solution (FTS). Depending on the requirements in each case, the WITTMANN **R9** control system can be equipped with the necessary interfaces.

Sonic 143 “chess robot”

With numerous interesting and out-of-the-ordinary applications at the K 2022, WITTMANN will illustrate the wide range of its robot series' different functionalities, while also demonstrating the high performance of its latest **R9** robot control system. One of these applications is the **Sonic 143** robot inviting visitors to a game of chess.



Sonic 143 robot from WITTMANN at the chess board.

This application makes use of the **Sonic 143's** outstanding functionalities as a high-speed robot. Basically, **Sonic** robots are the ideal equipment for short injection molding cycles with mold-open times of 1 second and below. These robot models are designed for extra high electrical and mechanical acceleration and deceleration rates – and maximal numbers of axis movements per minute. All of these possibilities are

used in the application shown, by reaching the shortest conceivable moving and manipulating times in handling the chess pieces.



A/C servo axis with gripper, chess piece.

The chess board is positioned vertically below the horizontal axis of the **Sonic 143**, to offer the human opponent and other onlookers the clearest possible view on the board and the development of the game. The robot is equipped with a combined **A/C servo axis** and an L-shaped gripper fitted with two individual magnetic gripping systems to handle the chess pieces. The second one of these two grippers comes into play whenever a chess piece is to be captured, that is, replaced by another piece on a particular field.

The chess pieces themselves were produced on a 3D printer and have a metal core, so that they can be moved by the metal grippers. The robot, the gripping systems and the chess software are all controlled by the latest WITTMANN **R9** robot control system. Thanks to its open program interface, this system allows the integration of an open-source chess software.

The **Sonic 143** has the option of playing either against itself or against a challenger from among the trade fair visitors. At the WITTMANN booth, all visitors are offered the opportunity to compete against the **Sonic 143** in a fast chess game with 3 min playing time, where they can enter their moves via a virtual chess board shown on the display of the WITTMANN **R9 TeachBox**.

WFC 120: flow controllers for up to 120 °C

For more than 40 years now, WITTMANN has been the number one in developing and manufacturing water distribution systems for the plastics industry. At the K 2022, WITTMANN will present the **WFC 120**, a cost-optimized digital flow controller able to monitor the flow rate and mold return temperature (or the difference between the mold supply and return temperatures) for each circuit. The flow rates in the individual circuits can be re-adjusted by means of manual control valves.

The **WFC 120** offers a choice of appliances ranging from 4 to 12 circuits (in steps of two). It comes with a 3.5" touch display via which the circuits are operated. On this display, the values of flow rates or temperatures are shown and monitored according to the tolerance margin entered.



WITTMANN WFC 120, 4-circuit model.

If the **WFC 120** is installed in an injection molding machine near the mold, it can be operated from outside the protective housing via a 5.7" remote control unit as an option. The data transfer to a WITTMANN BATTENFELD injection molding machine takes place via a proprietary communication protocol, which can also be made available for implementation in machines of other brands. As an option, a commercially available serial interface is offered, similar to those used for temperature controllers. In this way, the communication link can also be established with existing injection molding machines equipped with a serial interface.

The appliance comes in lightweight design, with the advantage of a low total weight. The parallel connection of the temperature control channels close to the mold made possible by the WFC120 ensures higher flow quantities, together with less wear on pumps, higher energy savings and lower maintenance expenses. With the available interfaces and data transfer to the machine, this is a useful tool for quality assurance. Where a direct link to the machine is not possible, logging can be carried out via a serial interface with the "DataLogger", which is also available as an option.

Smartphone app QuickLook 4.0

The new **QuickLook 4.0** app from WITTMANN has been completed in time for presentation at the K 2022. This app for iPhones and Android smartphones is a further development of the WIBA **QuickLook** app, which clearly displays essential process information for robots and injection molding machines. **QuickLook 4.0** has been brought into the stores parallel to the previous app, which means that both app versions are available for free-of-charge download from the Google play store and the Apple app store.

QuickLook 4.0 now provides a view into the entire **Wittmann 4.0** work cell. In addition to the injection molding machine and the parts removal robot, it will also support the entire range of **Wittmann 4.0** auxiliary appliances. A prerequisite for very easy applicability of the app is the presence of a **Wittmann 4.0** work cell router for each work cell. The router collects the information from the work cell and processes it for standard web communication. Existing work cells or appliances without a **Wittmann 4.0 Router** can also be visualized in the **QuickLook 4.0** app. All this requires is to procure a WITTMANN base controller for data collection and data processing, which is available separately, and have it integrated and configured in the production network.

So, unlike its predecessor app, **QuickLook 4.0** no longer communicates directly with the production equipment, but uses the **Wittmann 4.0** work cell router instead for deliberate decoupling of the interfaces. In terms of network communication serviceability, the router helps users to manage the balancing act between the very durable production equipment and the comparatively extremely fast changes of the IT world. At the same time, the **Wittmann 4.0 Router** offers the well-known advantages concerning firewall protection of the work cell network against malware.

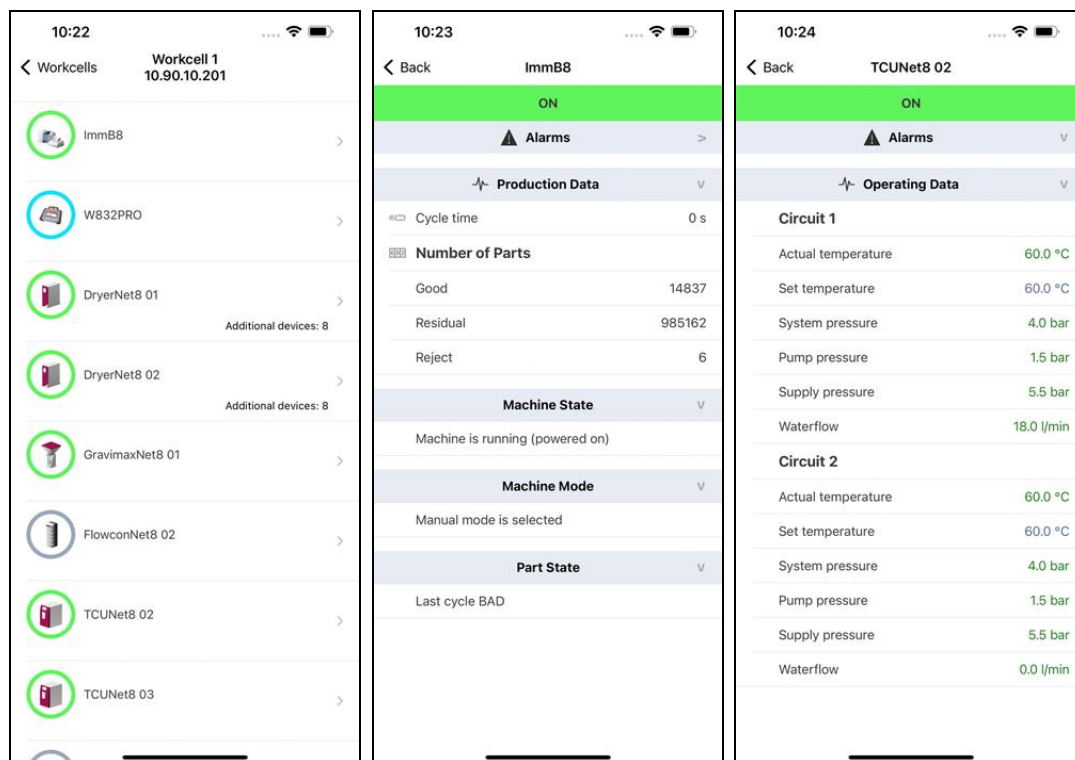

QuickLook 4.0 screen views – from left to right:
The appliances contained in a work cell; production data of the injection molding machine; operating data of a temperature controller.

In detail, the **QuickLook 4.0** app offers numerous interesting and useful features. For example, it provides an overview of the overall status of all participating work cells. For quick visual comprehension of the appliances' status, the operating mode of every unit is communicated via a color-coded display. The specific close-up views of essential operating data for each type of appliance can be retrieved, including alarm messages and process parameters. The listing of the work cells can be sorted user-

defined. Another work cell can be added very easily by simply scanning in a QR code from the injection molding machine's terminal. Configured work cells can be shared with other app users. The **QuickLook 4.0** app supports injection molding machines and robots, but also dryers, blenders, temperature controllers and flow controllers, as well as the **Airmould 4.0** module, the newly revised gas injection unit, and the **M8** central bulk material network control system.

Wittmann 4.0 ControlRoom TeachBox

At the K 2022, WITTMANN will present an extension to the **R9 robot TeachBox** named **Wittmann 4.0 ControlRoom TeachBox** – or, in short, **WCR TeachBox**.

The **WCR TeachBox** is a logical further development of the **Wittmann 4.0 Smart User Interface (UI)**, already familiar from the technology of **B8** injection molding machines, for the **R9 TeachBox**. The display and operation of HMIs of WITTMANN auxiliary appliances has thus become possible from the **R9 TeachBox** terminal, too.

This solution offers the display of a task bar at the bottom edge of the **TeachBox**, which enables users to navigate between the WITTMANN production appliances registered on the **Wittmann 4.0** work cell router.

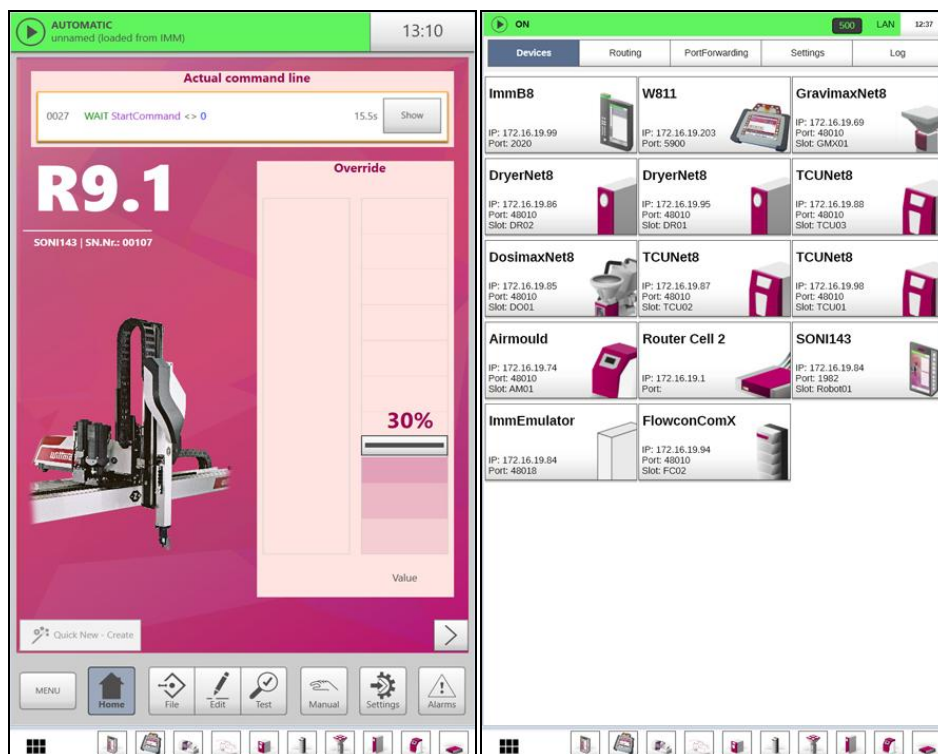

**Two screen views of the WCR TeachBox (from left to right):
Robot in the automatic mode; WITTMANN 4.0 router screen interface.
The task bar is shown at the bottom edge of the screen in each case.**

Depending on the type of appliance and UI technology used, up to two auxiliary appliances of the same type are allocated to each page. The system also supports

the newly revised WITTMANN **Airmould 4.0** gas injection technology. Here, the user interface of the **Airmould 4.0** module can even draw on the full high-resolution capacity of the **R9 TeachBox**, and when being operated from the **TeachBox** it provides an improved user experience without scrolling. In addition to the unique Smart UI approach for appliances compatible with **Wittmann 4.0**, complete operability of a **B8** injection molding machine and an **R8** robot via the proven VNC mirroring system is also provided.

As part of this new development, the concept of the digital **R9 Twin** has also been revised. The robot twin is no longer an integral part of the actual **R9** robot control system, but has now become available as a separately installable product for the **WCR TeachBox**. With the help of this robot twin, a teach program can also be created and optimized inline, that is, while the robot is being used in production in the automatic mode. Moreover, another digital twin has been developed for an injection molding machine. Together with both twins of the robot and the injection molding machine, the teach program for the robot can now be tested and optimized more simply, intuitively and completely than before. So, it has now become possible to use the services of the robot and injection molding machine twins in the background to simulate and estimate the future cycle time, while the teach program on the **WCR TeachBox** is still being written. This immediate, direct feedback draws the operator's attention to various subsequences, which may be in need of further optimization.

The chess display shown at the K, too, is based on the innovative technology of the **WCR TeachBox**. The chess board, on which visitors are invited to accept the challenge of a lightning chess game against the WITTMANN robot, is displayed – just like the auxiliary appliances – on the **WCR TeachBox** in the form of a Smart UI. Via the task bar, switching over from an **R9** application to the chess application and vice versa is possible at any time.

S-Max 1 granulator

The new **S-Max 1** granulator completes the WITTMANN range of low-speed screenless granulators. It is the ideal tool for inline-recycling beside-the-press. Low speed means high torque, less wear on cutting tools for reduced maintenance, low sound levels, low energy consumption. The low speed decreases noise and flyback during operation and provides a consistent regrind and better quality. This compact screenless granulator is ideal for inline recycling of sprues from injection molding machines up to 90 tons. The small footprint accommodates tight spaces and the wide-mouth, flared in-feed hopper easily handles a range of robot or conveyor drops and sprue/runner sizes.



***The new WITTMANN screenless
beside-the-press granulator S-Max 1.***

The **S-Max 1** is equipped with a knife and two toothed rollers and a cutting chamber with dimensions of 160 × 240 mm. The motorization is ensured by a gear motor of 0.75 kW placed vertically for the smallest possible footprint. The speed of rotation is 27 rpm ensuring maximum torque for the granulation of hard and brittle materials filled with glass fiber. The feeding hopper is made of stainless steel and ensures noise reduction. Easy and safe cleaning of the cutting chamber due to free access from the top.

The **S-Max 1** is the fourth granulator of its series of screenless **S-Max** granulators with up to 3 knives and cutting chamber dimensions of up to 240 × 467 mm. The **S-Max** series of granulators is perfect for the use with injection molding machines with clamping forces of up to 400 tons.

Materials handling: innovations for Gravimax

Ever since its market launch, the series of **Gravimax** blenders has been a synonym for highest precision and thus for maximal cost cuts in plastics processing. At the K 2022, WITTMANN is presenting the latest innovative features for this series of appliances.

By way of automatic formulation adjustment, **Gravimax** blenders ensure that the growing demand for feeding regrind, too, can be easily integrated into existing processes. As soon as regrind becomes available, the dosing formula is adapted automatically. Whenever additional regrind is created in the course of production – e.g., from additional reject parts – the **Gravimax** responds accordingly and increases the regrind fed in by a predetermined amount. Here, the main focus lies on a consistent material blend, in order to ensure a consistent quality standard for the end product – regardless of the proportion of regrind added to the blend. Even formulation changes can be made during ongoing operation without a production standstill. With this unique feature, **Gravimax** contributes to reducing the consumption of virgin material to a minimum and thus realizes significant cost savings.

Moreover, an OPC UA interface for automatic quality reporting is available, via which all process data can be retrieved for each batch. All **Gravimax** blenders are equipped with these functionalities as standard.

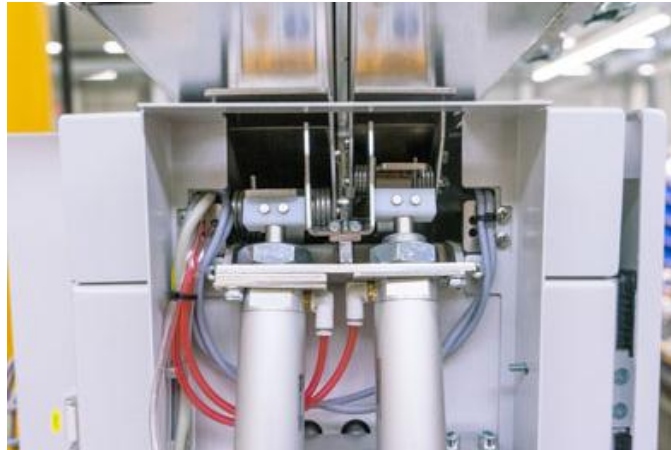

*View of the new dosing valves
of Gravimax blenders from WITTMANN.*

Another very significant innovation has been created with the dosing valve now being used in all new appliances of the series. The main purpose of this new development was to facilitate maintenance and servicing of these appliances. A special plastic material has been used to make the actuators of the dosing flaps. These new actuators have replaced the previously used PU dosing flaps and now ensure that servicing expenses can be almost completely dispensed with. This is another important step towards optimizing material costs as well as the regular maintenance costs in production.

Thanks to the wide range of applications for blenders from the **Gravimax** series, injection molding applications with material throughputs of up to 700 kg/h are able to benefit from all of these features.

Tempo plus D with SpeedDrive pump for ultimate energy efficiency

Energy consumption and the related issue of energy efficiency come up again and again as the number one topic at major events. Yet the discussion about energy efficiency has been going on in all areas of our society for a long time – in private circles as well as in the world of economics and industry. As a well-known manufacturer of temperature control equipment, WITTMANN also addresses this topic at the K 2022 in the challenging area of mold tempering. The aim is to achieve maximum energy efficiency in an area of the plastics processing industry with particularly high energy consumption.

The core of every stable injection molding process is extremely accurate temperature control in the mold inlet pipe, in conjunction with a parallel system pressure regulation governed by the inlet temperature. The global success of the **Tempo plus D** series

of temperature controllers from WITTMANN underscores the company's expertise, which is recognized by all of its customers. The objective of WITTMANN's K 2022 presentation is further growth of its market presence, not least in the special segment of pressure-superimposed **Tempro plus D** temperature controllers with energy-efficient, speed-controlled **SpeedDrive** pumps.



WITTMANN Tempro plus D160
temperature controller with SpeedDrive pump.

The use of a **SpeedDrive** pump offers a number of decisive advantages. From a choice of several control parameters for the FU pump, the user can select the one by which the process is to be kept constant on the selected control variable. The parameters available are: pump speed, pump pressure, flow quantity and differential temperature. Each selected control variable contributes to process optimization as well as to optimizing the energy consumption.

By setting a constant pump speed – between 1,200 and 4,000 rev/min, depending on the area of application – the product-specific energy consumption can be reduced substantially.

Regulation via the pump pressure discloses possible wear of the pump and/or the need for servicing if the set tolerance limits are exceeded. This serves to prevent costly damage to the pump. With this regulation method, the pump speed can be increased to up to 4,000 rev/min, as long as the pre-defined tolerance margin is not exceeded.

The flow quantity is measured in l/min by a VORTEX flow measurement device with an accuracy of $\pm 1.5\%$ of the maximum value. The set flow quantity is monitored within the tolerance limits. In the case of deviation beyond these limits, the pump speed is adjusted accordingly via the frequency inverter.

The differential temperature Δt is the control variable which discloses the degree of homogeneity in the temperature distribution inside the cavities. It is defined as the difference between mold inlet and mold outlet temperature. Once Δt has been calculated, this parameter can be set as control the variable and monitored within

tolerance limits. By reducing or increasing the pump speed, the set differential temperature is changed.

Regardless of the selected control variable, the advantage of a **SpeedDrive** pump is that it allows for a freely selectable pump speed in order to adjust the pump operating point to the ongoing process.

All pumps used by WITTMANN are exclusively equipped with motors of the efficiency class IE3; the degree of efficiency of a pump with a capacity of 1.1kW reaches 84.1%. The efficiency of **SpeedDrive** pumps ultimately depends on the user setting the optimal pump speed for each application. The lower the pump speed is set, the lower the power input of the pump will be, and the less energy will be consumed.

The WITTMANN Group

The WITTMANN Group is a globally leading manufacturer of injection molding machines, robots and auxiliary equipment for processing a great variety of plasticizable materials – both plastic and non-plastic. The group of companies has its headquarters in Vienna, Austria and consists of two main divisions: WITTMANN BATTENFELD and WITTMANN. Following the principles of environmental protection, conservation of resources and circular economy, the WITTMANN Group engages in state-of-the-art process technology for maximum energy efficiency in injection molding, and in processing standard materials and materials with a high content of recyclates and renewable raw materials. The products of the WITTMANN Group are designed for horizontal and vertical integration into a Smart Factory and can be interlinked to form an intelligent production cell.

The companies of the group jointly operate eight production plants in five countries, and the additional sales companies at their 34 different locations are present in all major industrial markets around the world.

WITTMANN BATTENFELD pursues the continued strengthening of its market position as a manufacturer of injection molding machines and supplier of comprehensive modern machine technology in modular design. The product range of WITTMANN includes robots and automation systems, material handling systems, dryers, gravimetric and volumetric blenders, granulators, temperature controllers and chillers. The combination of the individual areas under the umbrella of the WITTMANN Group enables perfect integration – to the advantage of injection molding processors with an increasing demand for seamless interlocking of processing machines, automation and auxiliaries.

Contact:

WITTMANN Technology GmbH
Lichtblaustrasse 10
1220 Vienna
AUSTRIA
Tel.: +43 1 250 39-0
info.at@wittmann-group.com

WITTMANN BATTENFELD Deutschland GmbH
Am Tower 2
90475 Nuremberg
GERMANY
Tel.: +49 9128 7099-0
info.de@wittmann-group.com

www.wittmann-group.com



Düsseldorf – October 19 to 26, 2022
WITTMANN at the K: hall 12, booth F23